



Sales, Manufacturing and Service Centres

South Africa
Benoni
Northern Cape
T +27 (0) 11 748 0000
F +27 (0) 11 421 2963
southafrica@davidbrown.com

Australia
Bulli
Mackay
Newcastle
Perth
T +61 (2) 4283 0300
F +61 (2) 4283 0305
australia@davidbrown.com

Chile
Antofagasta
T +56 (55) 492 800
chile@davidbrown.com

China
Changzhou
T +86 (0)519 8636 1256
F +86 (0)519 8636 1355
china@davidbrown.com

France
Thann
T +33 (0) 389 370 113
F +33 (0) 389 370 936
france@davidbrown.com

India
Bangalore
T +91 (80) 4205 8526
F +91 (80) 4205 8505
india@davidbrown.com

UAE
Dubai
T +971 (0) 4 887 0274
F +971 (0) 4 887 0275
dubai@davidbrown.com

UK
Huddersfield
T +44 (0)1484 465 500
F +44 (0)1484 465 501
uk@davidbrown.com

USA
Traverse City
T +1 231 946 8410
F +1 231 932 8002
usa@davidbrown.com

Sales Offices

Brazil
Sao Paulo
T +55 (11) 7027 7840
brasil@davidbrown.com

Chile
Santiago
T +56 (2) 234 5000
chile@davidbrown.com

Indonesia
Jakarta
T +62 (21) 5289 1871
F +62 (21) 5299 4599
indonesia@davidbrown.com

mining
power

The oil & gas industry driven by David Brown

rail
aftermarket
wind
solar

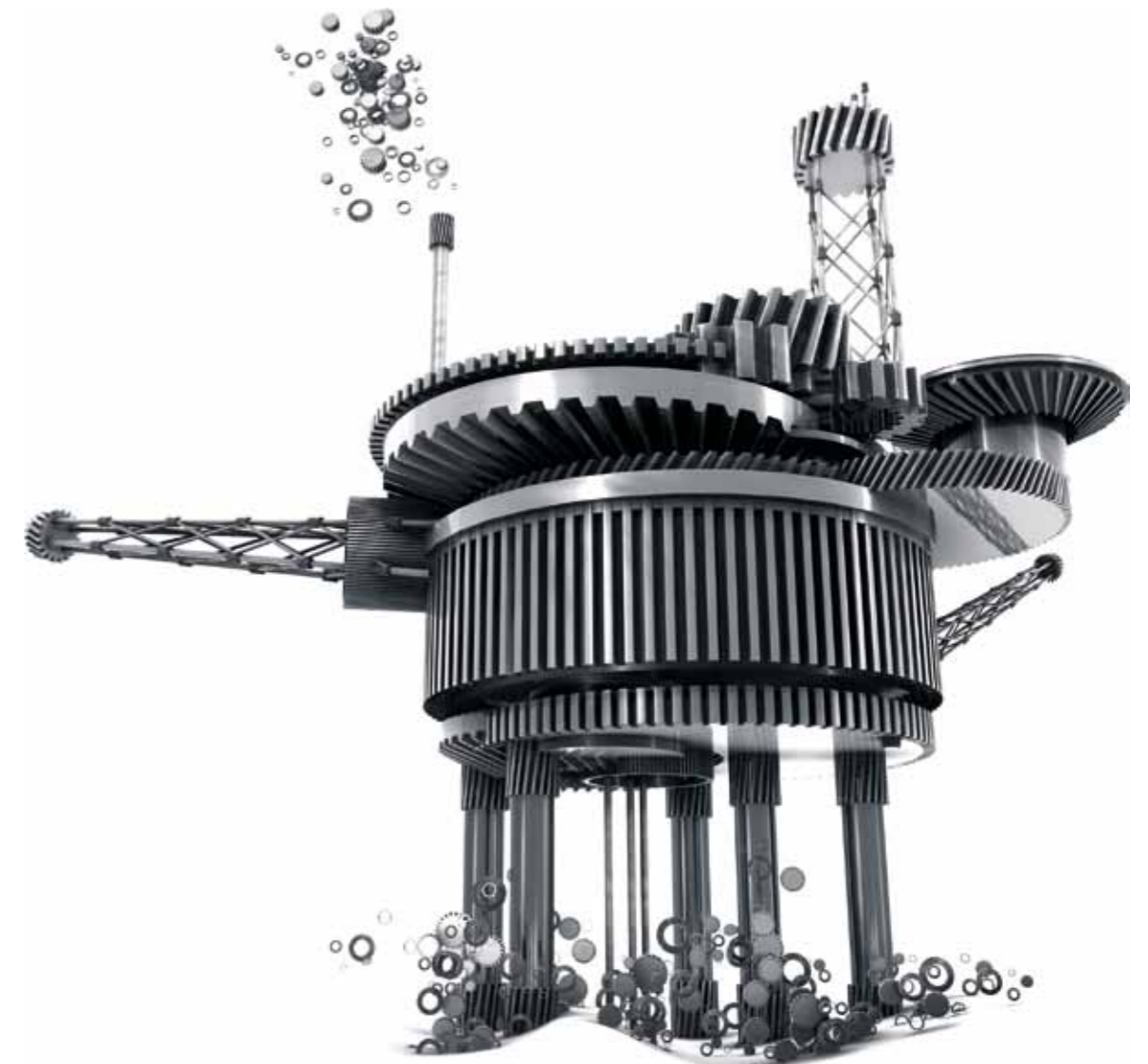

The oil & gas industry driven by David Brown

As developing countries and the emergent global economy drive an increasing demand for oil, gas and refined products from the petrochem process, there is no room for compromise on performance or reliability. In a world reliant on energy and petrochem products, system failure is not an option. That is why, across the whole up stream, mid stream and downstream, oil & gas related process stream, from bespoke engineered solutions to high quality Repair, Maintenance and Overhaul (RMO) programmes the world's leading companies turn to David Brown.

Working across various industrial sectors, David Brown goes to the very heart of the oil & gas industry, providing tailored gear products and systems, strategic maintenance and asset management services to all parts of the oil & gas process, including upstream exploration and extraction, through to mid stream transportation, and downstream processing. Our quality products and uncompromised service guarantee that drill contractors and refinery plant alike maintain optimum performance and minimise the risk of unscheduled downtime.

Worldwide, David Brown is considered a marque of quality engineering. The world's leading equipment manufacturers and engineering houses use our deep sector specific knowledge to augment their own engineering capabilities and meet both local and global operational objectives. Whether working with process and equipment designers to deliver robust, reliable systems or with oil & gas engineers to maintain optimum plant performance for longer, we pride ourselves on the quality of our work – and the assurance that it brings.

Our experienced teams know gear systems and the oil & gas sector inside out. Not only do we speak the language, we understand that engineering and maintenance teams need world-class oil & gas expertise on the ground 24/7. We have local expertise on-call to help solve all technical and operational problems even the ones waiting to happen. David Brown's global coverage means that, wherever the operation is, we are right there with you delivering the precision engineering and support you need.

ENGINEERED AROUND YOU: the name David Brown has been an integral part of industry for more than 150 years. This is because everything that we produce is driven by client needs. We completely immerse ourselves in the demands you face, because we know that the best way to solve a problem is to look at it from every possible angle. This is engineered around you.



David Brown – precision across the oil & gas process

No-one understands the demands of the oil & gas process better than David Brown. We see the big picture and understand that any process is only as robust as its weakest link. David Brown is geared to deal with any challenge, at every stage of the process, anywhere in the world, at any time. Our diverse experience of oil & gas, honed over decades of meeting complex engineering challenges in some of the world's harshest operating conditions, ensures the absolute reliability you need.



Upstream

Midstream

Downstream

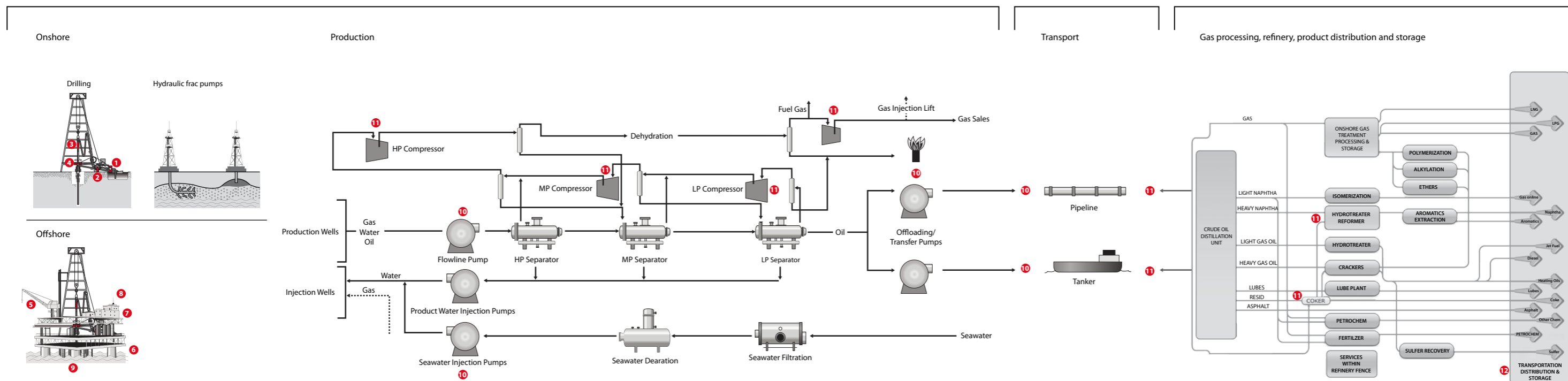

- 1 Mud/Frac pump drives
- 2 Drawworks gears
- 3 Top drive gears
- 4 Rotary table
- 5 Crane slew and winch gears
- 6 Jack up rig gears
- 7 Anchor winch
- 8 Gen-set high speed gears
- 9 Right angled fire water pump gears
- 10 High speed pump drive
- 11 Compressor drive
- 12 Process pump reducer drive

Drilling products

David Brown provides comprehensive solutions for gearing in capital drilling equipment including drawworks, mud and frac pumps, top drives and rotary tables. David Brown possesses an unrivalled ability to design, manufacture, commission and provide aftermarket service on a global footprint to enable us to meet all of the industry requirements for quality and reliability.

Top drive

Building to the customer's own designs, David Brown provides gearing expertise to top Drive manufacturers. Through our high quality build, assembly and test facilities, we utilise our global supply chain management process to offer Top Drive manufacturers a comprehensive turnkey gearbox solution.



Mud / Frac pumps

The nature of oil drilling requires products capable of handling the demands of arduous processes. David Brown delivers quality gearboxes for Mud Pump and Frac Pump applications to guarantee reliable running of these vital processes.



Drawworks

Drawworks comprise the key part in the drilling assemble. Drawworks parts are used for drilling, particularly in the tripping in and tripping out functions. Working closely with drawworks manufacturers, David Brown manufactures gearboxes to customers' designs or engineers to suit applications and provide increased safety, performance.

Jack-up rigs

There are important safety critical applications for gearing. Failure of these systems is not an option. David Brown has the experience, engineering, capability and high quality manufacturing processes to ensure reliability in its offerings. By working closely with our customers and engineering team, David Brown custom built products to match the exact specifications that are reliable and effective.

Jacking pinions

- Full manufacturing capability to DNV and ABS
- High Accuracy AGMA 14 after heat treatment
- Experience in different Module sizes



Jacking gearboxes

- Design and manufacturing capability for multi stage planetary and multi stage spur/helical gearing

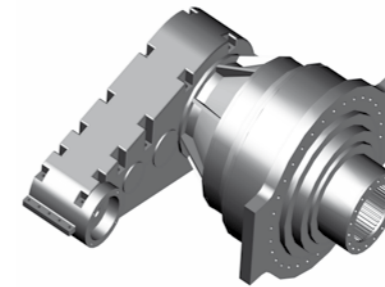

Rack chocks

- Experience in supplying electro mechanical rack chocks based on double enveloping worm technology



High speed gear boxes

David Brown has vast experience over many years in the oil & gas industry, supplying OEM's and end users with high speed gearboxes and transmissions. Choose from a large selection of ground gears for high-speed, high-torque and quiet transmission applications. Advanced high speed gearboxes have been supplied for: water injection pumps, generator sets, compressors, oil pipeline pumps, lift pumps and fire pumps.

Quality assured

David Brown supplies high quality high speed gearboxes that operate at speed beyond 40,000rpm to both OEM's and End Users. Our engineering flexibility allows us to build high quality solutions to exact specifications.

Key features:

- Designed to meet API, AGAM, DIN or ISO standards
- Supply and integration with stand-alone lubrication systems to supply the gearbox and driving and driven machines
- Integral gearbox sump lubrication systems
- Parallel Shaft or Planetary designs
- Full instrumentation packages (Vibration & Temperature Monitoring complete with Junction boxes suitable for the installed environment
- Barring drives and clutches designed and supplied to match the gearbox

Reliable and trouble free

By working closely with the customer we integrate the gearbox with lubrication and cooling systems that ensure reliability and a trouble free solution to your needs. Our flexible engineering approach allows us to help customers minimise pipe runs and rescue space requirements.

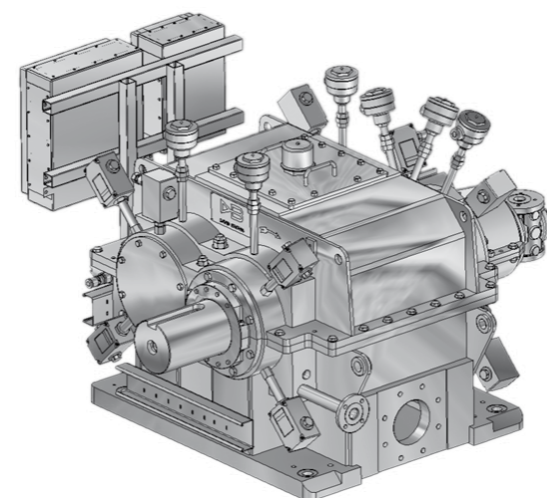

Minimise downtime

The demanding nature of the Oil & Gas and Power Generation Industries mean that downtime caused by gearbox failure is not an option. David Brown supplied gearboxes to the highest specifications providing a fit and forget solution.

Other oil & gas products

Within the oil and gas sector, David Brown offers a range of other products, which are customised and tailored to suit your requirements, offering agile and flexible designs. A proven track record of meeting the demands of the the oil and gas industry.

Firewater pump gearboxes

Operating as either speed reducers or increasers and with design to API677, David Brown has a long history of supplying quality spiral bevel gearing to the Oil & Gas Industry for vertical pump applications.

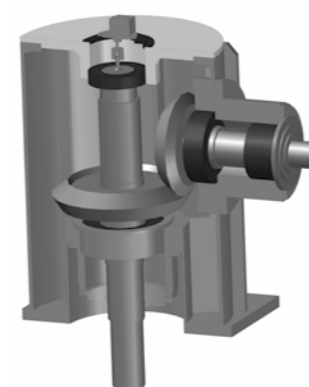

Speed reducing gearboxes

David Brown has experience in the design and build of gearing for all other Oil & Gas applications.

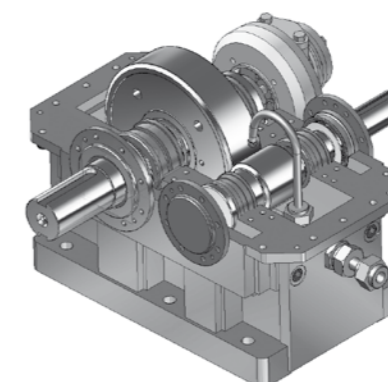

Additional oil & gas applications

- Crane Slew & Winch
- Anchor Winch



Full asset management

To improve process performance and reduce long term costs, David Brown's experience in asset management will allow you to concentrate on running your oil & gas business by allowing us to utilise the wealth of products and services with our renowned expertise. Together we will create a management strategy meeting your exact oil & gas requirements, maximising equipment availability, reliability and minimise the total cost of ownership through the life cycle of your equipment.

Oil, gas and petrochemical aftermarket services

- Pump drives
- Compressor drives
- Generator drives
- Top drives
- Jack up drives
- Reciprocating pumps
- Fire water pumps
- Ancillary drives
- Other bespoke pump/drive applications

Additional services

- On-site services
- Repairs, overhauls & upgrades
- Retrofit replacement gearboxes
- Asset management
- Condition monitoring
- Consulting, failure analysis and strain gauging



Global aftermarket

The support and service offered by David Brown is backed up by 150 years of expertise and experience. Dedicated aftermarket and support teams are based throughout the world. Giving you the vital support that you and your business demand on a global 24/7 basis. The expertise attained by David Brown ensures us to drive value into any overhaul or repair from simple to complex arrangements, either onsite or alternatively in one of our service centre facilities. Emergency repairs are available 24 hours a day 365 days a year, with full diagnostic and performance testing for all competitor drives including David Brown products.



- | | | |
|-------------------|-----------------|---------------|
| ○ Service centres | ● Sales offices | ● Planned |
| Australia | Brazil | North America |
| Chile | Chile | Peru |
| China | China | South Africa |
| France | Indonesia | |
| India | | |
| South Africa | | |
| UAE | | |
| UK | | |
| USA | | |