



**Sales, Manufacturing and Service Centres**

**South Africa**  
Benoni  
Northern Cape  
T +27 (0) 11 748 0000  
F +27 (0) 11 421 2963  
[southafrica@davidbrown.com](mailto:southafrica@davidbrown.com)

**Australia**  
Bulli  
Mackay  
Newcastle  
Perth  
T +61 (2) 4283 0300  
F +61 (2) 4283 0305  
[australia@davidbrown.com](mailto:australia@davidbrown.com)

**Chile**  
Antofagasta  
T +56 (55) 492 800  
[chile@davidbrown.com](mailto:chile@davidbrown.com)

**China**  
Changzhou  
T +86 (0)519 8636 1256  
F +86 (0)519 8636 1355  
[china@davidbrown.com](mailto:china@davidbrown.com)

**France**  
Thann  
T +33 (0) 389 370 113  
F +33 (0) 389 370 936  
[france@davidbrown.com](mailto:france@davidbrown.com)

**India**  
Bangalore  
T +91 (80) 4205 8526  
F +91 (80) 4205 8505  
[india@davidbrown.com](mailto:india@davidbrown.com)

**UAE**  
Dubai  
T +971 (0) 4 887 0274  
F +971 (0) 4 887 0275  
[dubai@davidbrown.com](mailto:dubai@davidbrown.com)

**UK**  
Huddersfield  
T +44 (0)1484 465 500  
F +44 (0)1484 465 501  
[uk@davidbrown.com](mailto:uk@davidbrown.com)

**USA**  
Traverse City  
T +1 231 946 8410  
F +1 231 932 8002  
[usa@davidbrown.com](mailto:usa@davidbrown.com)

**Sales Offices**

**Brazil**  
Sao Paulo  
T +55 (11) 7027 7840  
[brasil@davidbrown.com](mailto:brasil@davidbrown.com)

**Chile**  
Santiago  
T +56 (2) 234 5000  
[chile@davidbrown.com](mailto:chile@davidbrown.com)

**Indonesia**  
Jakarta  
T +62 (21) 5289 1871  
F +62 (21) 5299 4599  
[indonesia@davidbrown.com](mailto:indonesia@davidbrown.com)

**The cement industry driven by David Brown**





**ENGINEERED AROUND YOU:** THE NAME DAVID BROWN HAS BEEN AN INTEGRAL PART OF INDUSTRY FOR MORE THAN 150 YEARS. THIS IS BECAUSE EVERYTHING THAT WE PRODUCE IS DRIVEN BY CLIENT NEEDS. WE COMPLETELY IMMERSE OURSELVES IN THE DEMANDS YOU FACE, BECAUSE WE KNOW THAT THE BEST WAY TO SOLVE A PROBLEM IS TO LOOK AT IT FROM EVERY POSSIBLE ANGLE. THIS IS ENGINEERED AROUND YOU.

## Contents

The cement production process	06
Centre drives	08
The VMD series	10
Kiln drives	12
Global aftermarket support	17
David Brown gets Australian client out of a tight spot	18
Wash drum upgrade at Buxton Lime	19



**THE WORLD'S CEMENT INDUSTRY DRIVEN BY DAVID BROWN:** DAVID BROWN HAS THE KNOWLEDGE, EXPERIENCE AND EXPERTISE WITHIN THE CEMENT INDUSTRY THAT ONLY A COMPANY WITH OUR HERITAGE CAN DEMONSTRATE. WE PRIDE OURSELVES ON OUR ABILITY TO WORK WITH YOU, THE CUSTOMER, PROVIDING RELIABLE MAINTAINABLE SOLUTIONS.

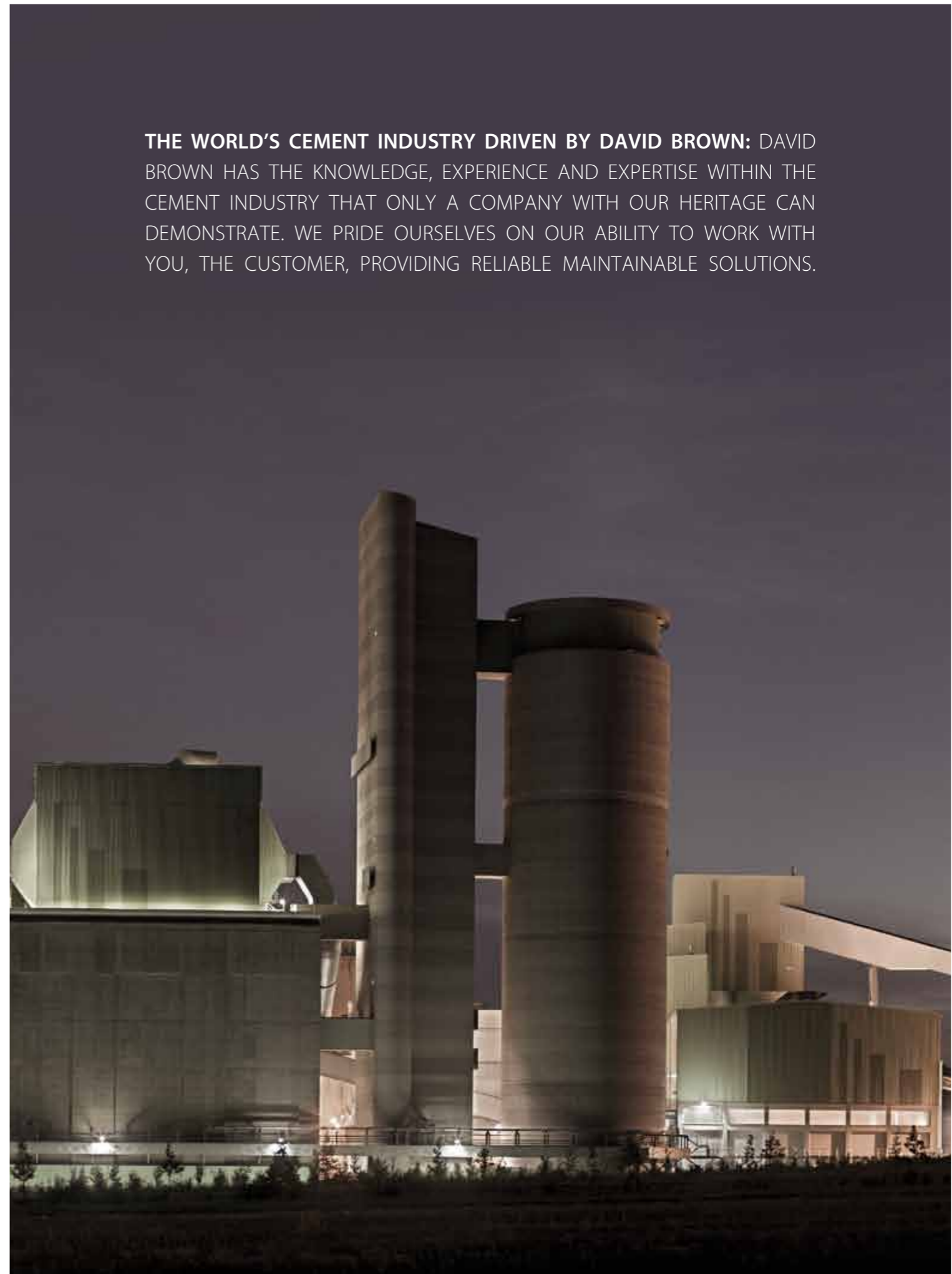

## The cement production process

David Brown excels in the cement industry because we supply products and services that our customers can fit and forget. Our continuous investment in design and engineering ensures our products and services reach the highest standards of accuracy, reliability and durability.

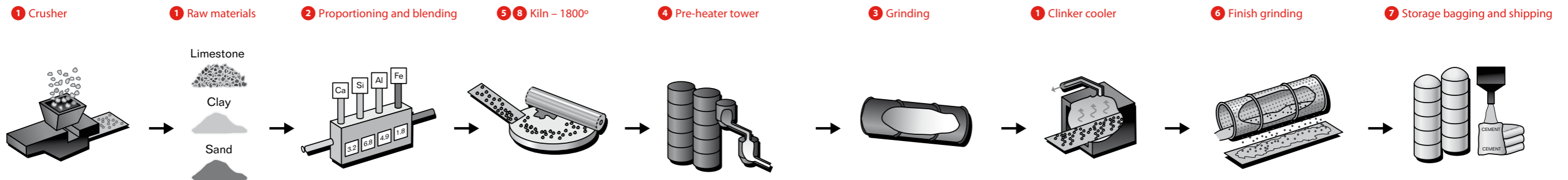

- ① Gearboxes for conveyor drives
- ② Gearboxes for conveyor drives
- ③ Vertical roller mill or ball mill drives – centre drives or girth gears and H Series
- ④ Gearboxes for screw conveyors, flap valves, rotary valves and dynamic separator drives

- ⑤ Kiln drives – girth gears, primary drives, centre drives
- ⑥ Mill drives for ball mills – girth gears, centre drives, twin planetary units, bevel helical, roller presses
- ⑦ Gearboxes for conveyor drives, bagging machines
- ⑧ Ball rolls and vertical roller mills for fuel grinding

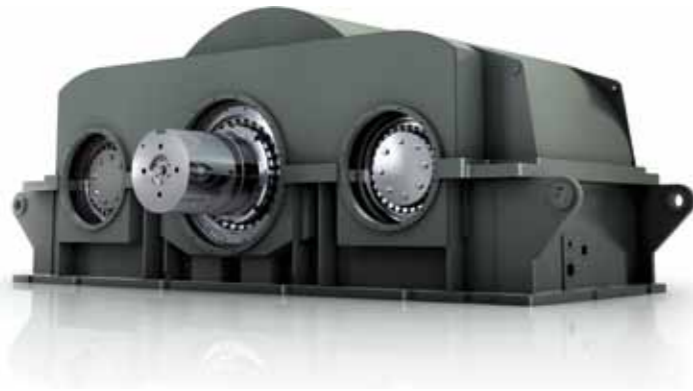

## Centre drives built for you

David Brown's design and engineering capabilities coupled with our extensive experience in the cement industry enables us to produce retrofit replacement gearboxes for existing installations that can run trouble free for 30 years or more.

The quality of the design and engineering work guarantees performance under the most extreme and demanding conditions and our gearboxes are better able to cope with the loading spikes often encountered in cement manufacture.

### Capabilities

David Brown utilises the latest engineering technologies such as 3D CAD and Finite Element Analysis (FEA) to ensure the work we produce performs to the high standards our customers expect from us. Our centre drive range runs from 1,500kw up to 10,000kw but each solution can be individually tailored to maximise the output of your cement plant.

### Maximised uptime

Our centre drives are designed to minimise downtime in the most difficult and harshest of environments and ensure your cement plant keeps on running. Quality engineering and the split torque design allowing for interchangeable parts not only ensures minimised spares holding but delivers maximum uptime.

### Easy installation & maintenance

Our centre drives are engineered for you, to allow for minimal disruption on installation and easy access for routine maintenance and inspections. The design of the base plates can be tailored to match existing centre heights ensuring our gearboxes are the perfect drop in solution for your cement plant.

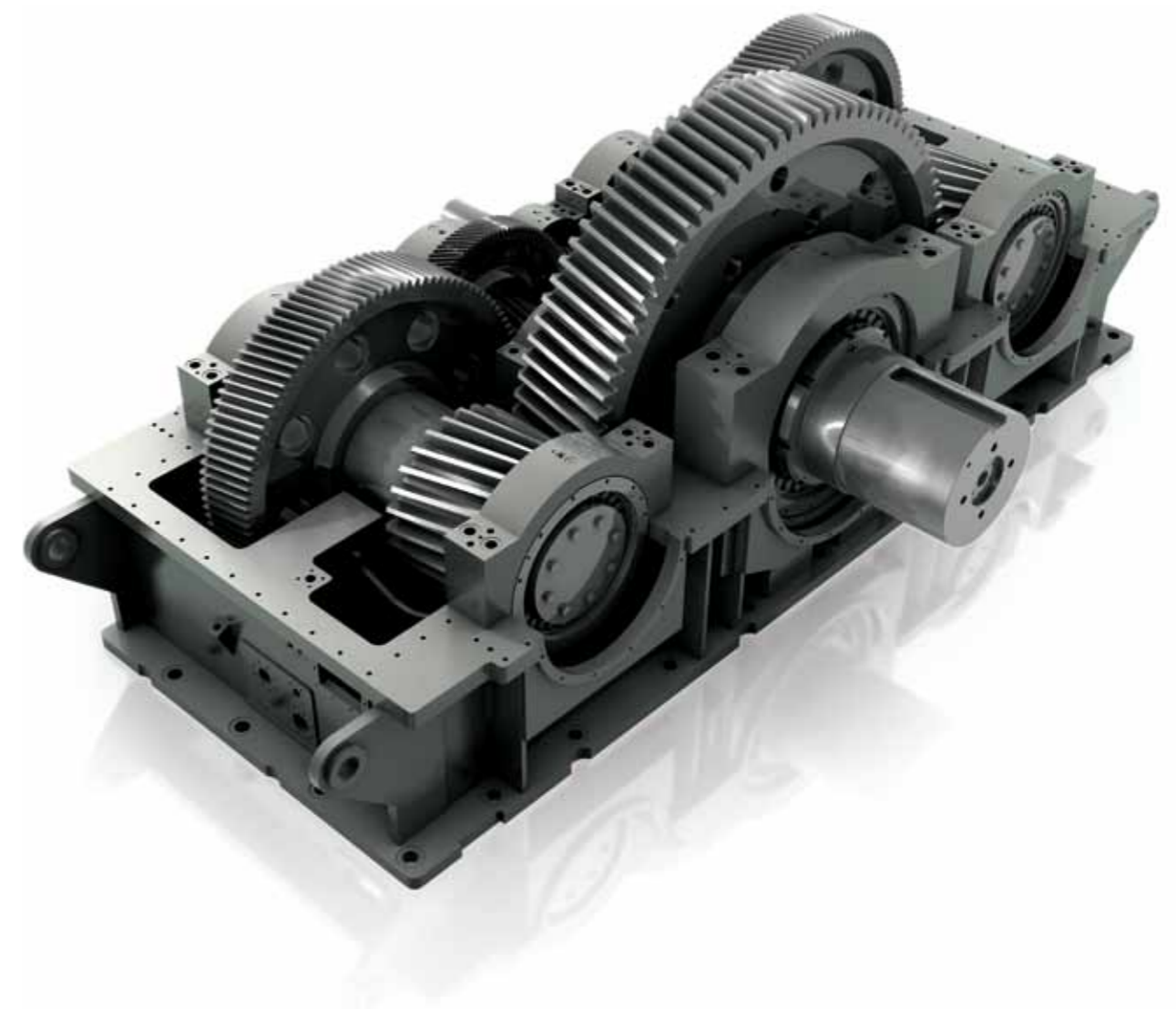

### Key features of centre drives

- Horizontal split gear case with top cover removable in less than 1 hour for easy inspection and maintenance
- Each gear can be removed and repaired independently with minimal disruption to other gears and shafts
- No overhung gears, i.e. all gear shafts supported by bearings at each end
- Optional auxiliary drive can be mounted to LH or RH of input shaft
- Main lubrication pump and standby lubrication pumps with automatic switching should one fail for any reason
- All gears are case hardened and profile ground for maximum precision, quietness and reliability utilising naval marine technology
- Identical LH and RH gear trains minimises spares stocking and allows the unit to run at reduced load should there be any problems
- All gear teeth are profile ground to AGMA Quality 12 (equivalent to ISO/DIN/BS Grade 5)



## The VMD series designed for you

The vertical mill drive is the ultimate combination of strength, integrity and precision and is ideal for demanding vertical mill crushing applications. Our engineering experience enables us to design customer matched solutions that will perform to the highest standards required under the most extreme and demanding conditions.

### Engineered for you

The vertical mill drive range runs from 250kW up to 1,600kW, but each solution can be individually tailored to provide optimised design for each customer's requirements up to 5,000kW if required. The adaptable design of floor mounting positions, shaft size and centre height ensures flexible designs to meet any requirement.

### Reliability

The advanced design of the VMD ensures it can handle 'overload' conditions as well as being a retrofit replacement for existing installations whilst offering durability and reliability. That's why it was ranked number 1 for reliability in the Chinese Federation of Electric Power Companies reliability index for 9 consecutive years.

### Minimise downtime

The VMD is designed to be reliable and durable but also to ensure when routine maintenance and inspections are needed downtime is kept to a minimum. The unique design of 4 removable inspection covers enables easy access and maintenance to be carried out without the need for lengthy and costly delays.

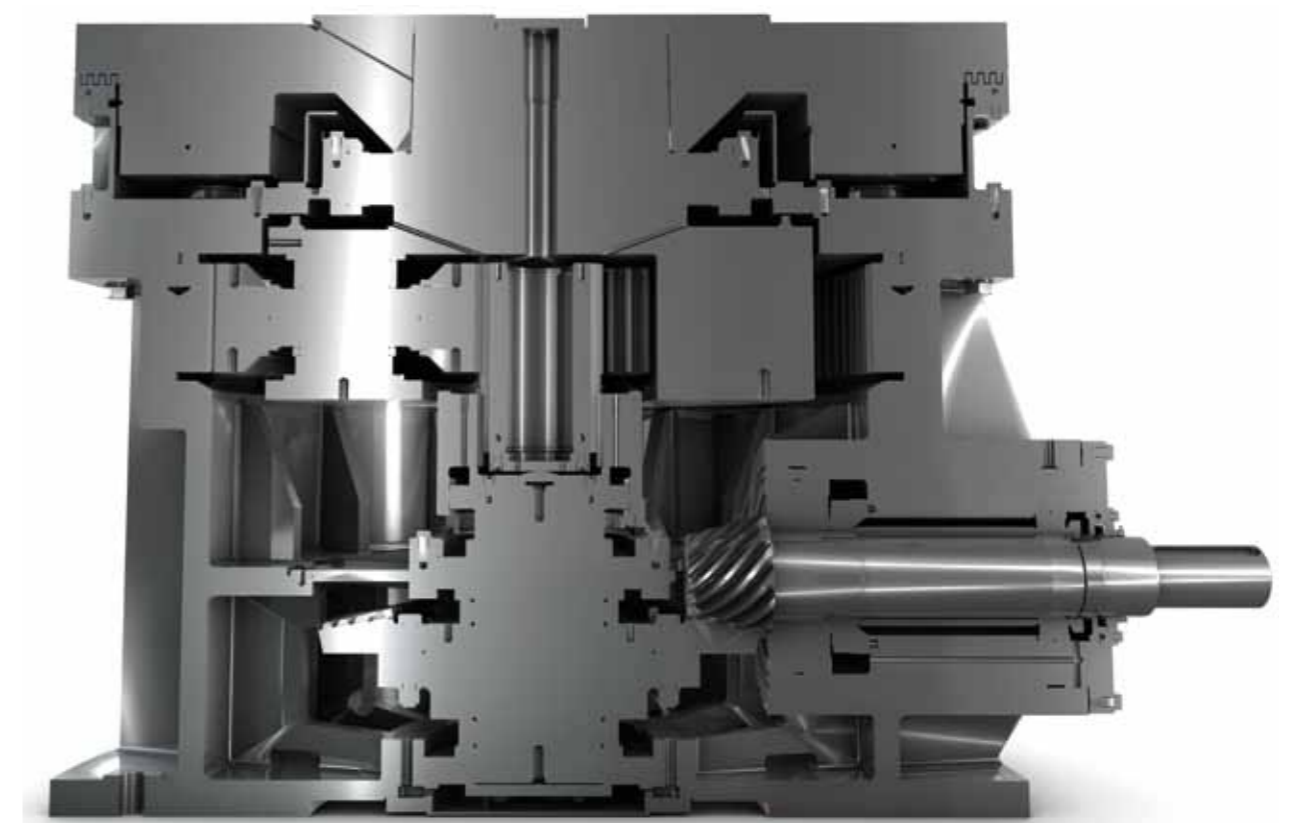

### Key features of the VMD series

- Single piece, SG iron cast planet carrier for high strength and integrity
- Planet gears case hardened, profile ground and supported in self-aligning roller bearings
- Labyrinth seals on input shaft and output coupling
- Input shaft supported with heavy duty roller bearings
- PTFE coated thrust pad bearings include temperature sensors to continuously monitor for dangerous overload conditions
- Through hardened high-alloy steel annulus enclosed within the case for additional strength
- SG iron, heavy-duty output coupling has hydraulic release for simple decoupling
- Case hardened and profile ground bevel gears
- 4 removable inspection covers allows easy inspection and replacement of thrust pad bearings without disturbing seal or output coupling.



## Kiln drives

The kiln is at the heart of the cement manufacturing process and that's why you require high quality reliable products to ensure continued operation. David Brown speed reducing gearboxes and girth gears are the high quality, reliable and durable products you need in this critical aspect of cement production to help keep your cement plant running.

### Speed reducer gearboxes

David Brown speed reducer gearboxes combine rigidity with strength and virtually eliminate backlash and friction. Designed to optimise speed, increase torque and improve the performance of your cement process without compromising on quality and reliability.

The David Brown speed reducer range operates up to 8,300kW and is a robust and durable product with low maintenance costs. The high quality profile ground helical gears coupled with a high level surface finish to ensure quiet running means a long life reliability which is critical in the demanding cement industry.

### Girth gears

David Brown is continually investing in the most advanced machining and gear cutting technology available today to ensure our girth gears are reliable and durable in the hostile environment of the cement industry.

David Brown has the global capacity to produce girth gears up to 14m diameter and can supply the world's largest kiln applications for the cement industry. With our temperature controlled gear cutting facilities you can be sure our gears achieve the highest accuracy possible - AGMA Grade 5.

### Key features of kiln drives

- David Brown speed reducing gearboxes combine rigidity with strength
- Speed reducing gearboxes are designed to optimise speed and increase torque
- All our gears are robust and durable with low maintenance costs
- Global capacity to produce girth gears up to 14m diameter
- Girth Gears to the highest accuracy possible (AGMA Grade 5)

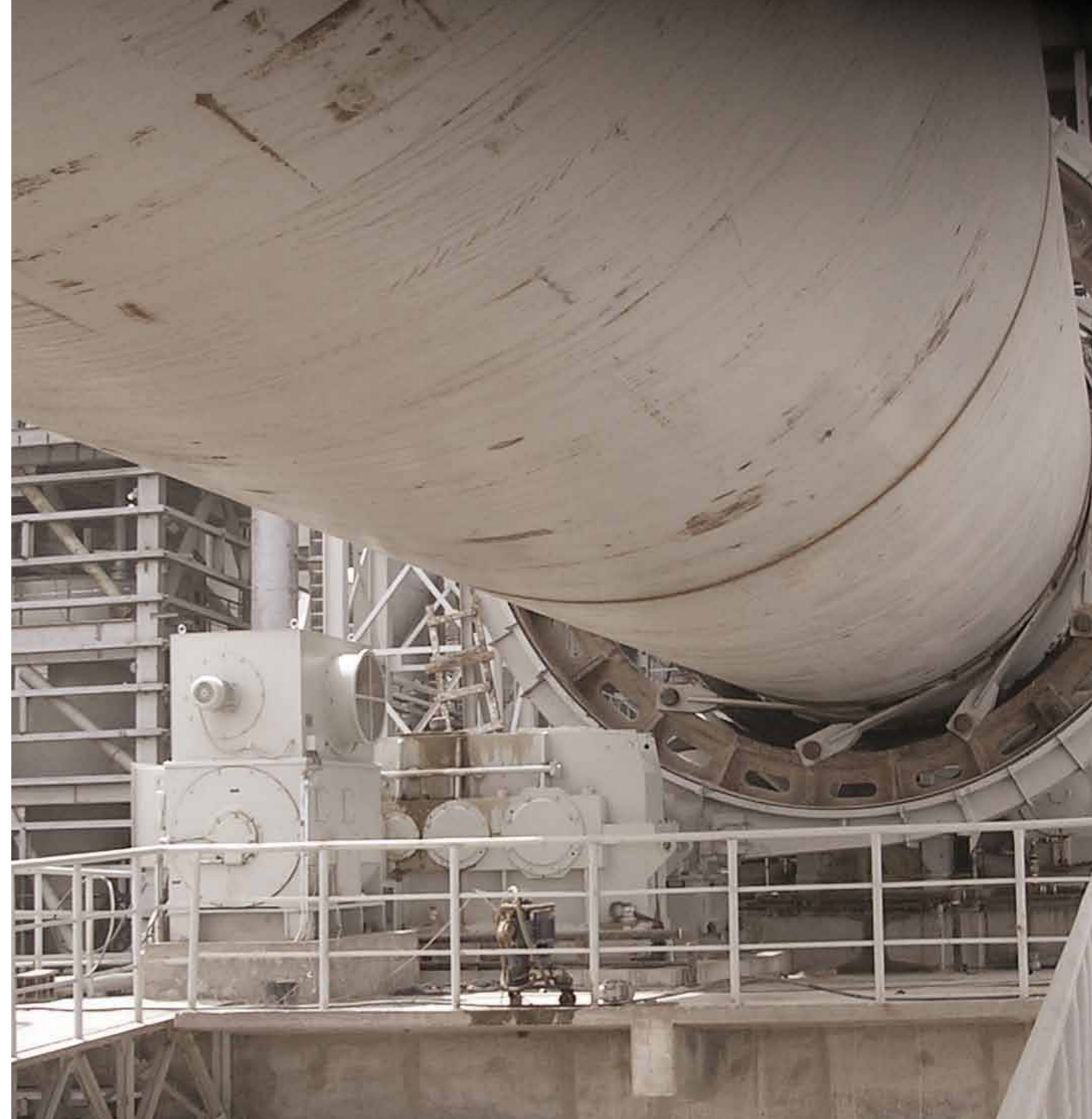



**SERVICE THAT YOU CAN COUNT ON:** DAVID BROWN IS DEDICATED TO MEETING OUR CUSTOMERS' NEEDS BY PROVIDING A SERVICE THAT OPERATES LIKE YOUR BUSINESS ON A GLOBAL 24/7 BASIS. THE QUALITY OF SERVICE AND SUPPORT OFFERED BY DAVID BROWN IS A DIRECT RESULT OF OUR EXPERTISE AND EXPERIENCE, BACKED BY THE QUALITY AND PRIDE OUR WORKFORCE DISPLAYS EVERYDAY. UTILISING THE LATEST TECHNOLOGY, OUR SERVICE ENGINEERS ARE READY AND WAITING 24 HOURS A DAY, 365 DAYS A YEAR.

## We operate at the very core of your business

David Brown has established a stand-alone, aftermarket business to take care of David Brown branded or any other geared installations, on a global basis. With the backing of dedicated proposals, engineering and purchasing teams, our products and services are truly engineered around you.

### Services offered

- On-site services
- Repairs, overhauls and upgrades
- Retrofit replacement gearboxes
- Asset management
- Strategic spares management

David Brown field service engineers are primed to deal with any problem you may encounter in the cement industry, anywhere in the world. Utilising the latest technology, they are ready and waiting 24 hours a day, 365 days a year.

Their specialist knowledge ensures that they can drive value into your process and keep your business running. They have the technology to provide fast, effective, repair and support services anytime, anywhere in the world.



## Global aftermarket support

The support and service offered by David Brown is backed up by decades of expertise and experience. We have a presence in five continents, serving local markets with locally employed teams of specialists. We pride ourselves on our ability to maintain long term relationships with our customers wherever they may operate in the world.



### Global support

- |                   |                 |               |
|-------------------|-----------------|---------------|
| ○ Service centres | ● Sales offices | ● Planned     |
| Australia         | Brazil          | North America |
| Chile             | Chile           | Peru          |
| China             | China           | South Africa  |
| France            | Indonesia       |               |
| India             |                 |               |
| South Africa      |                 |               |
| UAE               |                 |               |
| UK                |                 |               |
| USA               |                 |               |



### David Brown gets Australian client out of a tight spot

Overcoming extremely limited clearances while manoeuvring a 3m diameter, 23 tonne gear for an Australian cement producer is just the latest example of the resourcefulness regularly shown by David Brown's on-site services team.

The cement mill gearbox operated by a major Australian cement producer had suffered a bearing failure and resulting debris damaged the gear teeth. Engineers from David Brown not only attended the site to make repairs and allow continued production in the interim, but liaised closely with the client to plan the gear replacement method and keep downtime to a minimum.

The contract underlines the scope of David Brown's on-site services in a market which is increasingly driven by service as well as product excellence. In this case a special cradle was constructed under David Brown's guidance and the gear was transferred into place on rails.

Recognising the importance of preventative maintenance, the company also boasts a range of applications knowledge, gained through close long-term customer

partnerships in many heavy process industries, to offer performance improvements to transmissions and other rotating equipment. Using appropriate condition monitoring and analysis techniques, David Brown is able to pin point critical process issues and recommend courses of action to substantially reduce the associated risks.

The team that worked on the project is just part of David Brown's fully qualified field service engineer resource which is available

in most parts of the world to provide a number of key services from performance testing, fault diagnostics through to installation/commissioning, alignment checks and emergency repairs.

- Overcame extremely limited clearances
- Liaised closely with the client to plan gear replacement method
- Attended the site to make repairs and allow continued production
- Special cradle constructed
- Kept downtime to a minimum



### Wash drum upgrade at Buxton Lime

Tarmac's Buxton Lime quarry required replacement of the gearboxes on its No. 3 wash drums with the minimum of modification and production downtime. Ready product availability and expert technical assistance were going to be necessary to create a minimum of disturbance.

As a trusted supplier to the quarry over the years – over a hundred David Brown gearboxes are currently operating on the site – David Brown was approached to suggest possible replacements for existing gearboxes manufactured by a competitor.

The twin wash drums, motors and drives, which process a total of 2.5 million tonnes of material per annum, were supplied some years ago as a package and came already fitted with a competitor's gearboxes. As these gearboxes approached the end of their working lives a quote was obtained for their substitution on a 'like-for-like' basis but by this stage the model had gone out of normal production and was prohibitively expensive, with a significant delay in availability, whilst

an 'equivalent' product in their range would have required too much modification to be practicable, hence the attraction of the David Brown solution.

The washing plant at Tarmac's Buxton Lime plant produces hydrated limes used for a soda ash process in Cheshire and for flue gas desulphurisation at three power stations in the East Midlands.

Aiming to get as close as possible to a 'drop in' solution, David Brown's sales team liaised

closely with the quarry, inspecting the installation and providing detailed drawings and advice necessary to enable the work to be carried out. The gearboxes were customised to feature specially-shortened output shafts and needed only re-drilling of the base plate and the use of packing plates to raise the shaft centres to the correct height. The installation work took a total of sixteen hours while a further gearbox is being kept on site as a strategic spare.

- Replaced gearboxes with minimum modification and production downtime
- Over 100 David Brown gearboxes on site
- The gearboxes were customised to create an effective solution
- Ready product availability and expert technical assistance
- Minimum downtime